



CCO/Win

Wheel Alignment System

Owner's Manual



CCDWin Wheel Alignment System

Owner's Manual

© Copyright 1995, Automotive Diagnostics, A Division of SPX Corporation

Table of Contents

Chapter 1: Introduction

CCDWin Wheel Alignment System Basics 1-2

CCDWIN ALIGNMENT SYSTEM FEATURES 1-2

ABOUT THIS MANUAL 1-2

Notes, Cautions & Warnings 1-2

Conventions 1-2

Keyboard 1-2

Shortcut Keys 1-2

Pointing Devices 1-2

Light Pen 1-2

Moving the Pointer 1-2

Making Your Selection 1-2

Highlighting Text 1-2

Mouse or Trackball 1-2

Moving the Pointer 1-2

Making Your Selection 1-3

Highlighting Text 1-3

Making Selections 1-3

SAFETY PRECAUTIONS 1-3

Power Cord Connections 1-3

Wet Floors 1-3

Vehicle 1-3

Raising the Vehicle 1-3

GETTING STARTED 1-3

KEYBOARD 1-4

REMOTE CONTROL UNIT 1-4

WHEEL UNITS 1-4

Wheel Unit Keypad 1-4

Runout 1-4

Caster Swing 1-4

Camber/Caster 1-4

Toe/Track 1-4

Drawing/Text 1-4

Jack & Hold 1-4

Backup 1-4

Continue 1-4

Wheel Unit LEDs 1-4

WHEEL CLAMPS 1-5

PRINTERS 1-5

Vehicle Preparation	1-5
PUTTING VEHICLE ON RACK	1-5
SELECT WHEEL CLAMP HOOKS	1-5
Wheel Clamp Hook Installation	1-6
INSTALL THE WHEEL CLAMPS	1-6
INSTALL WHEEL UNITS	1-6

Chapter 2: Icons

Icons: Pictures and Definitions	2-2
Add User-Defined Record	2-2
Adjustment Drawings	2-2
Adjustment Information	2-2
Adjustment Meters	2-2
Alignment	2-2
Animation	2-2
Backup	2-2
Belts	2-2
Brake Inspection Test	2-2
Brakes	2-2
Calculator	2-2
Cancel	2-2
Caster Swing	2-2
Clear	2-2
Clock/Calendar	2-2
Confidence Check	2-2
Continue	2-2
Customer Data	2-2
Delete	2-2
Display/Hide Saved Readings	2-2
Display/Hide Specifications	2-2
Drive Test	2-2
Edit Vehicle Specifications	2-3
Exhaust	2-3
Exit	2-3
Filters	2-3
Fluid Leaks	2-3
Fluids	2-3
Hardware Information	2-3
Help	2-3
Hoses	2-3
Jack & Hold	2-3
Maintenance Reminder	2-3
OK	2-3
Perform Inspection Test	2-3
Print	2-3
Programmed Alignment	2-3

Icons: Pictures and Definitions (cont')

Runout	2-3
Save	2-3
Select All	2-3
Service	2-3
Setup	2-3
Software Information	2-3
Steering	2-3
Steering Test	2-3
Suspension	2-4
System Utilities	2-4
Tires	2-4
Turn Angle	2-4
Under-Car	2-4
Underhood	2-4
Vehicle Data	2-4
Visual Inspection	2-4
Zoom	2-4

Chapter 3: Main Menu

MAIN MENU OVERVIEW	3-2
Selections	3-2
PROGRAMMED ALIGNMENT OVERVIEW	3-2
ALIGNMENT OVERVIEW	3-3
CUSTOMER DATA OVERVIEW	3-3
VEHICLE DATA OVERVIEW	3-3
VEHICLE INSPECTION OVERVIEW	3-4
VISUAL INSPECTION TESTS	3-4
Group Tests	3-4
Individual Tests	3-4
SYSTEM UTILITIES OVERVIEW	3-5
Clock/Calendar	3-5
Maintenance Reminder	3-5
Calculator	3-5
Confidence Check	3-5
Setup	3-5
Facility Information	3-5
Programmed Alignment: Customizing Procedures	3-5
Service	3-5
Printer Options	3-5
Hardware Information	3-5
Software Information	3-6
Help	3-6
Exit	3-6
HELP SYSTEM OVERVIEW	3-6
EXIT	3-6

Chapter 4: Alignment

Runout	4-2
RUNOUT OVERVIEW.....	4-2
Wheel Unit LEDs	4-2
Normal Runout Mode	4-2
Optional Runout Modes	4-2
4-Point Runout	4-2
All Wheel Runout	4-2
Special Runout.....	4-2
Caster Swing.....	4-3
CASTER SWING OVERVIEW.....	4-3
Turn Angle	4-3
TURN ANGLE OVERVIEW.....	4-3
Jack & Hold.....	4-3
JACK & HOLD OVERVIEW	4-3
Display All.....	4-4
DISPLAY ALL OVERVIEW.....	4-4
2-Wheel Only	4-4
2-Wheel Center Line	4-4
4-Wheel Thrust Line	4-4
Front	4-4
Rear.....	4-4
8-Sensor	4-4
Front	4-4
Rear.....	4-4
Adjustment Meters	4-4
ADJUSTMENT METERS OVERVIEW	4-4
Operating Toe and Caster/Camber Meters.....	4-4

Chapter 5: Preventive Maintenance

Preventive Maintenance	5-2
WHEEL ALIGNMENT RACK/RUNWAYS.....	5-2
FULL FLOATING FRONT TURNING RADIUS PLATES.....	5-2
REAR SLIP PLATES	5-2
SLIDING JACKING BEAM	5-2
CCD ALIGNMENT SYSTEM UNIT	5-2
BRAKE PEDAL DEPRESSOR	5-2
STEERING WHEEL HOLDER	5-2

Chapter 1: Introduction

CCDWin Wheel Alignment System Basics

ABOUT THE CCDWIN ALIGNMENT SYSTEM

CCDWIN ALIGNMENT SYSTEM FEATURES

The CCDWin Alignment System has the following features:

- Windows-based software using an icon format allowing quick movement through the alignment program.
- The ability to switch between languages, including printing in a different language than the one displayed on-screen.
- A user-programmable alignment sequence.
- An SVGA swivel monitor.
- Context-sensitive Help with illustrations.
- Summary pages showing all alignment angles with specifications and more.
- A "zoom" feature for the adjustment meters to allow easy viewing from a distance.
- A vehicle specification database, visual inspection, enhanced 3D adjustment illustrations and animations, and 6- or 8-sensor CCD wheel units to accurately calculate alignment angles.

ABOUT THIS MANUAL

This manual includes vehicle connections, operation and maintenance procedures. It is broken down into the following chapters:

1. **Introduction:** Introduces the CCDWin Alignment System's components.
2. **Icons:** Shows all icons and their function.
3. **Main Menu:** Describes the operation and features of the Main Menu.
4. **Alignment:** Describes all of the CCDWin Alignment System's tests and functions.
5. **Preventive Maintenance:** Includes necessary procedures for maintaining your unit.

NOTES, CAUTIONS & WARNINGS

Throughout this publication, you will notice three levels of reminders:

NOTE

Note reminders highlight important information such as exceptions or helpful hints.

CAUTION

Caution reminders call your attention to special instructions required to prevent damage to the unit or vehicle.

▲ WARNING ▲

Warnings indicate the potential for personal injury unless you take precautionary steps. Carefully read warnings before continuing!

CONVENTIONS

- **Keyboard**—When making selections on CCDWin Alignment System screens, you have the choice of using the pointing device or keyboard shortcuts. Most Windows users find they can be more efficient using the keyboard shortcuts. Key commands are always enclosed in square brackets []. In some cases, you may need to press two or more keys at once. A "+" symbol appears between the bracketed keys to indicate the keys should be pressed together. For example, "press [ALT] + [C]" indicates you should press the keys marked "ALT" and "C" at the same time.

NOTE

When instructed to press keys, do *not* press the square bracket "[]" or "+" keys.

- **Shortcut Keys**—If a text selection on the screen has an underlined character, shortcut keys are available. Press [ALT] and the underlined letter to select the item. For example, the shortcut keys for Close are [ALT] + [C].
- **Pointing Devices**—The CCDWin Alignment System is equipped with an optical "touch-screen" light pen. You can also use an optional mouse or trackball as your pointing device.

LIGHT PEN

—**Moving the Pointer:** Hold the light pen about an inch away from the screen and move the pen in the desired direction. The pointer "follows" the pen.

—**Making Your Selection:** When the pointer is over the icon or screen selection, gently touch the screen selection.

—**Highlighting Text:** First, gently touch the appropriate text field. Next, firmly press the light pen down against the desired text and "drag" the pen across the text.

MOUSE OR TRACKBALL

—**Moving the Pointer:** Simply slide the mouse or roll the trackball in the appropriate direction. The pointer will follow.

--- **Making Your Selection:** When the pointer is over the icon or screen selection, click the left button on the mouse or trackball.

--- **Highlighting Text:** Press and hold the left button as you drag the mouse over the text or roll the trackball.

- **Making Selections—The CCDWin Alignment System** gives you several options for making screen selections:
 - Gently touch the desired option with the CCD Alignment System light pen.
 - Click the desired option with left mouse or track ball button.
 - Move the cursor to the selection using the [TAB] or [Shift]+[TAB] keys. Press [ENTER].
 - Press the appropriate shortcut keys, if available.

SAFETY PRECAUTIONS

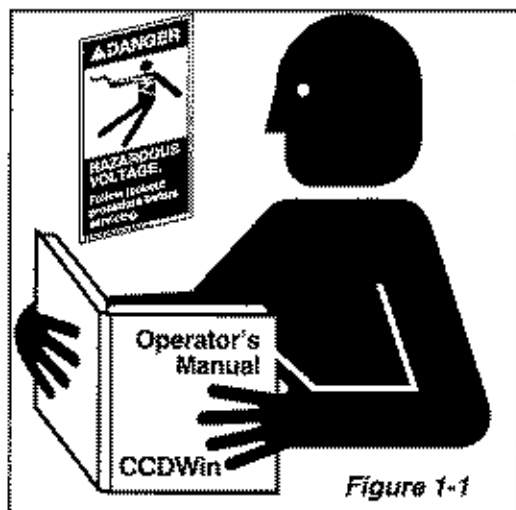

The automobile service area can be a dangerous environment if you don't take the proper safety precautions. This is a brief list of precautions you can take to operate the CCDWin Alignment System safely. Make sure all operators understand the safety precautions in this section.

▲ WARNING ▲

Failure to acknowledge the warnings that follow could result in injury or death!

POWER CORD CONNECTIONS

▲ WARNING ▲

- The alignment machine must be plugged into a properly grounded outlet.

- Do *not* cut the grounding prong off the AC power cord.
- If using a ground adapter, be sure the pigtail is grounded to the power receptacle.
- If an extension cord is used, use a three-wire type with the grounding circuit in good condition.

WET FLOORS

▲ WARNING ▲

When plugging unit power cord into electrical outlet, avoid wet floors to prevent electrical shock.

VEHICLE

▲ WARNING ▲

MAKE SURE THE VEHICLE CANNOT ROLL. Block the wheels if necessary to keep the vehicle from rolling off the rack.

RAISING THE VEHICLE

▲ WARNING ▲

Use a jacking system appropriate for the vehicle being aligned.

GETTING STARTED

1. At each power-up the boot program automatically starts CCDWin Alignment software and displays the Main Menu.
2. If other applications have been running, return to the Windows Program Manager and select the CCDWin Alignment icon in the Wheel Alignment group. The CCD Alignment System Main Menu is displayed. (See Chapter 3 for more information.)
3. When the CCDWin software is installed and started for the first time, you are prompted for an authorization number. To receive this number, contact your local distributor. (In the U.S., call 1-800-833-3377.) You are allowed 50 "free" operations of the CCDWin Alignment program before authorization is required to continue use.
4. To begin performing an alignment on a vehicle, refer to "CCD Alignment Mode" in the Help system Table of Contents.

KEYBOARD

The keyboard is a standard personal computer keyboard. Use it to type in customer data or to access other computer applications.

REMOTE CONTROL UNIT

The keys on the Remote Control Unit provide the operator with the advantage of being able to operate a vehicle inspection program while "at the vehicle". Some of the remote keys serve dual purposes.

The Remote Control Unit also provides a remote display of wheel angles. The display shows both adjustment meters and alignment values.

Use the remote unit to:

- Enter and exit the meter screens;
- Choose wheels for display on meter screens;
- Perform the visual inspection routines.

WHEEL UNITS

Wheel Units (Figure 1-2) contain sensors which measure wheel position. During alignment, wheel units are mounted to rim clamps attached to the wheel rims of the vehicle under test.

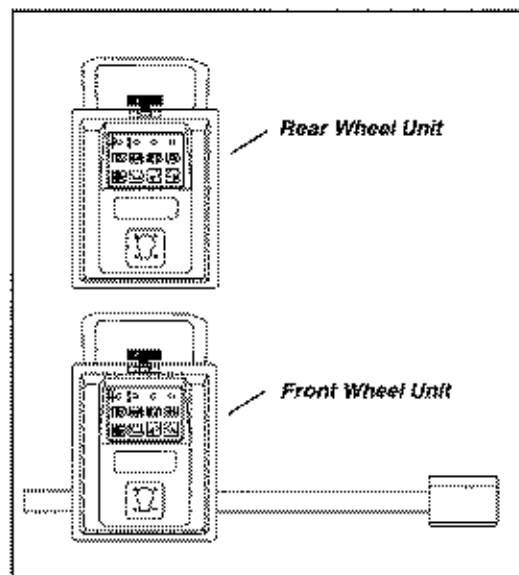

Figure 1-2

NOTE

In 8 sensor kits, the rear wheel units are the same as the front wheel units. A decal designates which are the rear wheel units.

WHEEL UNIT KEYPAD

The wheel unit keypad consists of eight keys used for alignment control at the wheel unit (see Figure 1-3).

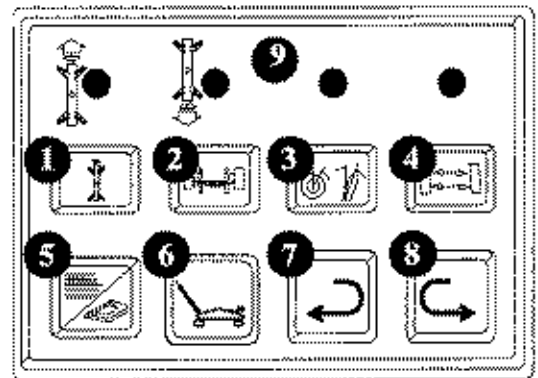

Figure 1-3

The keys function as follows:

- 1 RUNOUT**—Start the Runout Procedure from either the "Display All" page or the Main Menu. Once in Runout mode, the runout key is used to take measurements in the different "KNOB..." positions at a given wheel unit.
- 2 CASTER SWING**—Start the "Caster Swing" procedure from the "Display All" page.
- 3 CAMBER/CASTER**—Select adjustment meters from the "Display All" page or from Meter screens.
- 4 TOE/TRACK**—Select adjustment meters from the "Display All" page or from Meter screens.
- 5 DRAWING/TEXT**—Steps through diagnostic drawings and associated text screens when specifications are loaded. It is active from the "Display All" page and Meter screens.
- 6 JACK & HOLD**—Select to display readings when the wheels are jacked up.
- 7 BACKUP**—Go back one step in the procedure currently running.
- 8 CONTINUE**—Go forward to the next step in the procedure.
- 9 WHEEL UNIT LEDs**—Each wheel unit has four LEDs which display wheel status during runout. See "Runout" discussion in the "Alignment" section for details.

NOTE

The [BACKUP] and [CONTINUE] icon keys on each wheel unit work the same way as the [BACKUP] and [CONTINUE] prompts displayed on the screen by the software. They are used to move backward and forward through the alignment screens.

WHEEL CLAMPS

Wheel clamps are four-armed clamps that attach to a vehicle's wheels (see Figure 1-4). They provide spindles for hanging the wheel units. A wheel clamp spindle centers itself as the clamp is tightened on a rim.

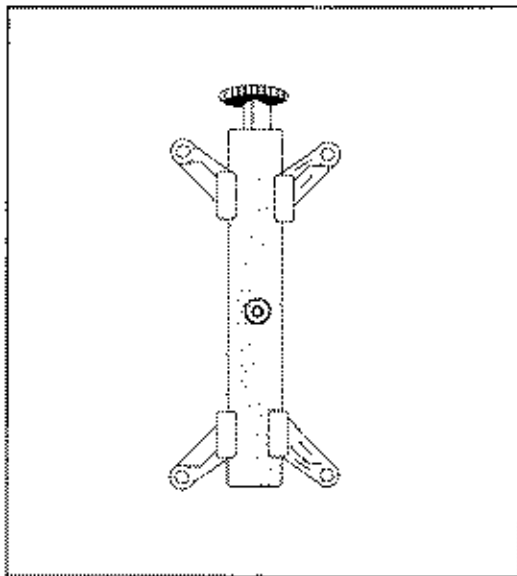

Figure 1-4

PRINTERS

For instructions on how to install paper or the removal and replacement of the printer ribbon, refer to the instructions supplied with your printer.

To prepare a vehicle for alignment procedures, follow these instructions carefully.

PUT VEHICLE ON RACK

1. Lock turning plates into position with pointers at the zero degree mark.
2. Drive the vehicle onto the rack. Position the front wheels in line with the zero mark of the turning plates.
3. If rear toe/camber is to be adjusted, rear wheels must be on slip plates.
4. Chock the wheels or take other steps to make sure the vehicle cannot roll.

WARNING

It is important to make sure the vehicle is securely positioned on the rack and the vehicle **CANNOT ROLL**.

SELECT WHEEL CLAMP HOOKS

NOTE

A stud at the end of each wheel clamp arm holds hooks which attach themselves to the wheel when the clamp is installed. Select the proper type of hook to be used according to the type of wheel on the vehicle.

These studs have two different types of hooks (see Figure 1-5):

- Wheel Hooks—rest against the inside edge of the wheel. These hooks fit most style wheels.
- Rim finger hooks—grasp the outer rim of a wheel along the edge of the tire bead. These hooks fit wheel styles which prevent the use of the wheel hooks.

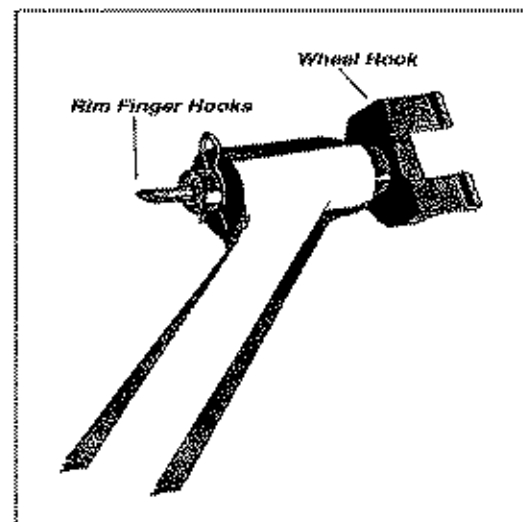

Figure 1-5

Vehicle Preparation

WHEEL CLAMP HOOK INSTALLATION

To change hooks, turn the studs around in the arms as follows:

1. Remove the hairpin clip that retains the stud.
2. Remove the stud from the arm and turn it around.
3. Put the stud back in the arm and reinstall the hairpin clip.

INSTALL THE WHEEL CLAMPS

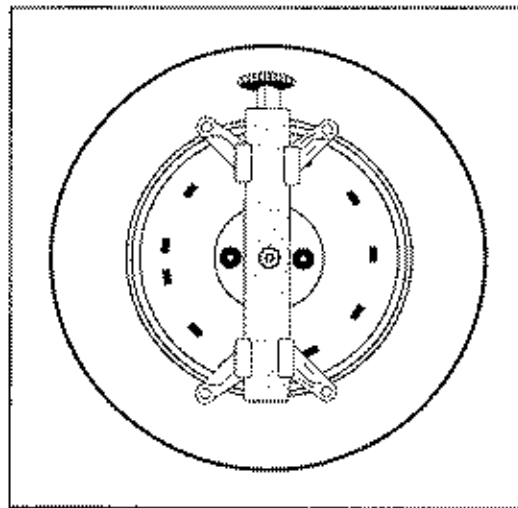

Figure 1-6

1. To attach a clamp to a wheel, position the large black knob toward the top of wheel (see Figure 1-6). Set the lower hooks against the wheel rim (or hook them around the bottom edge of the rim, depending on which hooks are used).

NOTE

On some vehicles, the body sheet metal prevents the wheel clamps from being mounted at 12 o'clock and 6 o'clock. If so, mount the clamps in the 3 o'clock and 9 o'clock position.

2. Turn the black knob to bring top hooks into place. Avoid wheel weights, burrs, or dents. Make sure the hooks seat properly.
3. Turn the knob tightly to secure the clamp to the wheel so it doesn't move.
4. Pull on the clamps to check for tightness.

The wheel clamp spindle centers itself as the clamp is tightened to the rim.

NOTE

Wheel runout compensation is done electronically by the alignment machine. Do *not* adjust wheel clamps to compensate for wheel runout.

INSTALL WHEEL UNITS

Each wheel unit is designed for a specific wheel position. They are *not* interchangeable from wheel to wheel.

1. Position the wheel units so there is a line-of-sight between the left- and right-front sensors, and a line-of-sight from the front sensors to the rear sensor on each side of the vehicle.
2. Slide the wheel units onto the wheel clamp spindles as shown in Figure 1-7 below (the figure shows a rear wheel unit, only).
3. Use the level vial on each wheel unit to level the unit. Tighten the black knob on the wheel unit to secure the unit on the spindle.
4. If the front wheel units' line of sight is obstructed, they may be tipped down slightly to see past the obstruction.

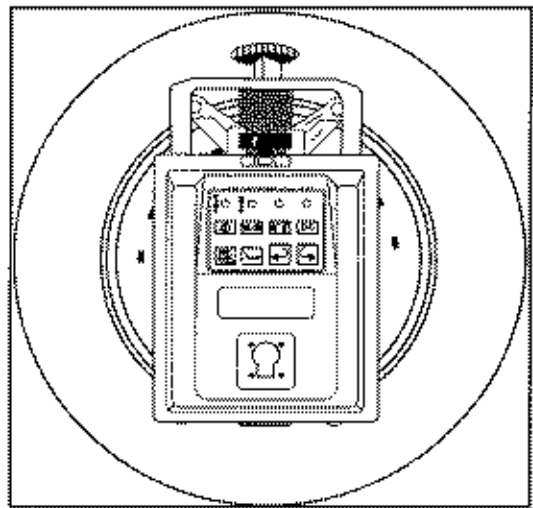

Figure 1-7

Chapter 2: Icons

CHAPTER CONTENTS

This chapter describes and shows examples of the icons available to you in the CCDWin software.



Add User-Defined Record

Allows you to name and add the edited/catered specifications to the user-defined data base.



Adjustment Drawings

Proceeds to the Adjustment Illustrations screen.



Adjustment Information

Allows you to run other alignment related software, such as shim selection.



Adjustment Meters

Proceeds to the Adjustment Meters screen.



Alignment

Begins a basic alignment sequence that includes Runout and a Display All screen of alignment readings.



Animation

Allows you to view an animation based on the adjustment illustration.



Backup

The function of this can vary. It can display a previous screen.



Belts

Proceeds to the Belts Visual Inspection screen.



Brake Inspection Test

Proceeds to the Brake Inspection Test Visual Inspection screen.



Brakes

Proceeds to the Brakes Visual Inspection screen.



Calculator

Proceeds to the calculator function in System Utilities.



Cancel

Cancels the action you were performing and returns you to the previous screen.



Caster Swing

Proceeds to the Caster Swing screen.



Clear

Clears the data you entered.



Clock/Calendar

Proceeds to the clock/calendar function in System Utilities.



Confidence Check

Proceeds to the confidence check function in System Utilities.



Continue

The function of this can vary. It can display the next screen.



Customer Data

Allows you to save and retrieve customer information.



Delete

Deletes the data displayed on-screen from the database.



Display/Hide Saved Readings

Toggles between the display/hide modes for saved readings on Display All screen.



Display/Hide Specifications

Toggles between the display/hide modes for vehicle specifications on Display All screen.



Drive Test

Proceeds to the Drive Test Visual Inspection screen.

**Edit Vehicle Specifications**

Proceeds to the Edit Vehicle Specifications screen.

**Exhaust**

Proceeds to the Exhaust Visual Inspection screen.

**Exit**

Exits the CCDWin software, system utilities, or service.

**Filters**

Proceeds to the Filters Visual Inspection screen.

**Fluid Leaks**

Proceeds to the Fluid Leaks Visual Inspection screen.

**Fluids**

Proceeds to the Fluids Visual Inspection screen.

**Hardware Information**

Proceeds to the hardware information function in System Utilities.

**Help**

Activates the CCDWin's context-sensitive help system.

**Hoses**

Proceeds to the Hoses Visual Inspection screen.

**Jack & Hold**

Proceeds to the Jack & Hold screen.

**Maintenance Reminder**

Available in System Utilities. Proceeds to the Maintenance Reminder screen.

**OK**

Accepts data and proceeds to the next screen.

**Perform Inspection Test**

Proceeds to the checklist screen for the selected Visual Inspection tests.

**Print**

Prints the on-screen data. In the System Utilities Menu, this icon is used to setup the printer.

**Programmed Alignment**

Begins an alignment sequence that you can customize to include any alignment steps.

**Runout**

Used to proceed to the Runout screen, and is used for each wheel when performing runout.

**Save**

Saves the alignment readings from the Display All-screen.

**Select All**

Selects all the tests on the Visual Inspection screen.

**Service**

Proceeds to the service function in System Utilities (available to Service personnel *only*).

**Setup**

Proceeds to the Setup screen.

**Software Information**

Proceeds to the software information function in System Utilities.

**Steering**

Proceeds to the Steering Visual Inspection screen.

**Steering Test**

Proceeds to the Steering Test Visual Inspection screen.



Suspension

Proceeds to the Suspension Visual Inspection screen.



System Utilities

Allows you to modify system preferences and to use the CCDWin's tools, system configurations for hardware/software, clock/calendar, and others.



Tires

Proceeds to the Tires Visual Inspection screen.



Turn Angle

Proceeds to the Turn Angle screen.



Under-Car

Selects all the Under-Car tests on the Visual Inspection screen.



Underhood

Selects all the Underhood tests on the Visual Inspection screen.



Vehicle Data

Proceeds to the vehicle specification selection screen.



Visual Inspection

Allows you to inspect a variety of vehicle components and print a report for the customer.



Zoom

Allows you to enlarge an adjustment illustration or adjustment meter.

Chapter 3: Main Menu

MAIN MENU OVERVIEW

SELECTIONS

There are 8 selections along the top of the Main Menu screen (see Figure 3-1):

- Programmed Alignment
- Alignment
- Customer Data
- Vehicle Data
- Visual Inspection
- System Utilities
- Help
- Exit



Figure 3-1



Programmed Alignment

PROGRAMMED ALIGNMENT OVERVIEW

Selecting [PROGRAMMED ALIGNMENT] from the Main Menu allows the operator to run a Programmed Alignment sequence which can be customized to include any of the alignment procedures listed below. This mode allows you to customize the alignment procedure to best suit your needs. You can rearrange the sequence of alignment steps or eliminate certain steps altogether.

Use the Setup function in the System Utilities Menu to change the Programmed Alignment sequence, if necessary.

The default sequence for Programmed Alignment is as follows:

- Customer Data
- Specifications
- Visual Inspection

- **Runout**—Must be included at some point in the sequence before *Caster Swing* and/or *Display All Page*, since it is necessary for accurate alignment measurements.
- **Caster Swing**
- **Turn Angle**
- **Display All**—Automatically occurs last in the Programmed Alignment sequence.

From the *Display All* page the operator may access *Camber* and *Toe Meter* screens, with live indicators to assist in adjusting values to specifications.

The operator may print the customer report at the end of the alignment procedure.

ALIGNMENT OVERVIEW

Begins a basic alignment sequence that includes Runout and a Display All Page of alignment readings. Some readings are live and others are calculated.

Selecting [ALIGNMENT] from the Main Menu runs a measurement procedure with two general parts:

- **Runout**—An automated procedure to detect and compensate for any offset in the position of the wheel clamp spindles and for bent rims. Perform runout before taking any alignment measurements (unless special rim clamps are used that require "no runout").
- **Display All Page**—Once runout has been performed, a screen appears that shows "live" camber and toe readings, setback values, and thrust line values. From this Display All screen an icon can be selected which will add the calculated caster and SAI values to the screen.

CUSTOMER DATA OVERVIEW

The Customer Data program allows you to enter new customers, search for existing customers based on name, license, or work order, and delete customers. This screen is divided into following areas:

- Customer Data (name, address, phone, etc.);
- Vehicle Data (license, VIN, make, model, etc.);
- Work Order Data (work order number, technician, etc.).

VEHICLE DATA OVERVIEW

The Vehicle Data program allows you to select a vehicle based on a combination of the following:

- Database;
- Manufacturer;
- Year, Model and Options.

Edit User Specifications allows you to customize the various vehicle specifications (toe, camber, etc.).

Add User-Defined Record allows you to add a record to the User-Defined database. Enter the information in the appropriate text fields and select [CONTINUE].

Adjustment Illustrations gives you text with adjustment help, and full-color 3-D illustrations and animations available for the selected vehicle.

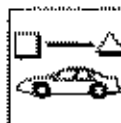

Alignment



Customer Data



Vehicle Data



Visual Inspection

VEHICLE INSPECTION OVERVIEW

Vehicle Inspection can be selected directly from the Main Menu or included as part of a Programmed Alignment.

The Visual Inspection procedure guides the operator through a list of components or items to inspect. Indicate the condition of each item by selecting the appropriate condition displayed on-screen (OK, Worn, etc.). The results of this inspection can be printed from the Vehicle Inspection screen or at the end of the alignment procedure from the Display All page.

Select the [VISUAL INSPECTION] icon from the Main Menu. The Visual Inspection screen appears.

VISUAL INSPECTION TESTS

Several tests are available to you in Visual Inspection. You may select one or all of the tests if desired. You may also select groups of tests like Underhood, etc.

The following inspection options are available to you.

GROUP TESTS



Select All

Selects all the tests.



Underhood

Selects all under-hood tests.



Under-Car

Selects all under-car tests.

INDIVIDUAL TESTS



Drive Test



Steering Test



Brake Inspection Test



Fluids



Belts



Filters



Hoses



Exhaust



Fluid Leaks



Tires



Brakes



Steering



Short/Long Arm Suspension



Macpherson Strut Suspension



System Utilities



Figure 3-2

SYSTEM UTILITIES OVERVIEW

The System Utilities Menu (Figure 3-2) allows access to the various system utilities. Following is a list of the System Utility options.



CLOCK/CALENDAR

The Clock/Calendar feature is available on the System Utilities Menu. The Clock/Calendar displays the current system month, date and time. You can also view system maintenance reminders on the Clock/Calendar screen.



MAINTENANCE REMINDER

The Maintenance Reminder feature is available on the System Utilities Menu. Selecting this option displays a list of all maintenance items due on the CCDWin unit. After this button is selected, and the information is viewed, the button appears "ghosted" until the next time maintenance items are due.



CALCULATOR

The Calculator is accessible from the System Utilities Menu and performs five functions:

- Addition
- Subtraction
- Multiplication
- Division
- Percentage Conversion



CONFIDENCE CHECK

The Confidence Check is accessible from the System Utilities menu. This option is a procedure to check the calibration of the wheel units.



SETUP

The Setup screen is accessible from the Utilities menu, or any time the icon appears. This screen allows you to configure the system according to your preferences. You can choose alignment and runout modes, languages, units of measurement for displays and identify any optional hardware installed on your unit.

The following screen items can be configured on the Setup screen:

Facility

The CCDWin Alignment System can personalize your printed reports with your facility name, address, and message.

Programmed Alignment

The CCDWin software features a Programmed Alignment mode which allows you to customize the alignment procedure to best suit your needs. You can rearrange the sequence of alignment steps or eliminate certain steps altogether.



SERVICE

The Service icon is accessible from the Systems Utilities menu. The service software is *only* available to service technicians.



PRINTER OPTIONS

The Printer Options icon is accessible from the Systems Utilities menu. The Printer Options menu allows you to change the format of printed reports produced by the CCDWin Alignment System, the report language, and the printer selected.



HARDWARE INFORMATION

The Hardware Information screen is accessible from the Systems Utilities menu. This screen provides information about your system's hardware configuration, such as the type of processor, display, keyboard, language, and pointing device installed.

The Hardware Information screen also provides version numbers and the most recent calibration date for the CCDWin Alignment System wheel units.

NOTE

This is a read-only screen. You can not add, delete or modify any of the information displayed.



SOFTWARE INFORMATION

The Software Information screen is accessible from the Systems Utilities menu. This screen provides information about your system's software configuration. It includes the version numbers for MS DOS, Windows, and the alignment program.

NOTE

This is a read-only screen. You can not add, delete or modify any of the information displayed.



HELP

Context-sensitive Help for the Systems Utilities Menu. Select the icon or press [F1] to access Help. If you are already in the Help system, pressing [F1] displays instructions for using the Help system.



EXIT

Selecting this icon will exit the System Utilities Menu and return you to the Main Menu.



Help

HELP SYSTEM OVERVIEW

The CCDWin software includes a powerful on-screen help system. The help system operates just like help systems for other Windows-based software applications. Help is available from any screen. To use the help:

- Select the Help icon;
- or
- Press [F1].

NOTE

Pressing [F1] while using the CCDWin software displays help for the screen you are using. If you are already in the Help system, pressing F1 displays instructions for using the Help system.



Exit

EXIT

Exits the CCDWin software and returns you to the Windows operating environment.

Chapter 4: Alignment



Runout

RUNOUT OVERVIEW

Runout is included in every alignment procedure, before either the Caster Swing or the Display All Page. Runout detects and compensates for any offset in the position of the wheel clamp spindles and for bent rims. This is important for accurate alignment measurements.

WHEEL UNIT LEDs

Each wheel unit has four LEDs which display wheel status during runout.

The far left LED on the wheel unit indicates the runout status in the "KNOB DOWN" (KNOB at 6 o'clock) position. The second LED from the left indicates the runout status in the "KNOB UP" (KNOB at 12 o'clock) position. These two LEDs are used in Normal Runout and All Wheel Runout modes.

During 4-point Runout, the third LED from the left indicates the runout status in the "KNOB LEFT" (KNOB at 9 o'clock) position. The far right LED indicates the runout status in the "KNOB RIGHT" (KNOB at 3 o'clock) position.

When an LED is lit, the alignment program is ready to take runout readings in the corresponding rim clamp position. After readings are taken in a particular rim clamp position, another LED illuminates to indicate the next rim clamp position.

NOTE

Runout must be performed each time wheel clamps are installed. If rim clamps are removed from a wheel to allow repairs or alignment adjustments to be made, the runout procedure must be performed again for that wheel only. As long as the rim clamps on the other wheels have not been removed, their runout calculations will remain valid.

On-screen messages and pictures provide guidance through the Runout procedure. Perform the following instructions for each wheel.

NOTE

Start with any of the wheel units. Runout can be performed in any order.

⚠ WARNING ⚠

Do not lower the vehicle without locking the brakes first (use the pedal depressor and/or parking brake) to prevent the vehicle from rolling! Failure to follow this procedure could result in injury or death!

NORMAL RUNOUT MODE

This mode checks the runout at two points—the "KNOB DOWN" 6 o'clock position, and the "KNOB UP" 12 o'clock position. The process requires you to rotate each of the wheels 180 degrees. After the first wheel has been checked for runout, you then proceed to rotate the remaining wheels, one at a time.

OPTIONAL RUNOUT MODES

These optional modes are selected from the Setup screen in the System Utilities menu.

4-Point Runout

This runout mode allows you to install a rim clamp and wheel unit, and perform runout compensation all in one procedure.

If you choose this option, the CCDWin Alignment System uses the wheel unit camber vials (rather than the toe/track beams) to calculate runout.

NOTE

The 4-Point Runout process *must* start at the 9:00 o'clock position, and each wheel *must* be rotated *counter-clockwise*.

All Wheel Runout

This runout mode calculates runout on all of the wheels at the two positions, 6:00 o'clock and 12:00 o'clock, as the vehicle is rolled forward and backward.

All Wheel Runout prompts you to roll the vehicle forward or backward until the wheels rotate 180 degrees, then back to the starting point.

Choose this option if you cannot jack the vehicle off the ground.

Special Runout

Choose this option if you have special rim clamps that do not need runout compensation performed.

CASTER SWING OVERVIEW

Most often, Caster Swing is done as part of the Programmed Alignment sequence. However, it can also be selected from the Display All screen by pressing the caster swing key on a wheel unit, or selecting the Caster Swing icon on the Main Menu.

Caster swing is a procedure to measure caster, included angle and SAI (Steering Axis Inclination). Caster swing must be repeated each time an adjustment is made to update the data that appears on the summary or "Display All" screen. In an automated sequence, the operator turns the wheels to specified points while the computer takes measurements and performs calculations.

After a caster swing is performed, caster and SAI values will be displayed on the Display All screen, along with the other alignment measurements.

TURN ANGLE OVERVIEW

"Turning Angle" is most often included as part of the "Programmed Alignment" sequence. It can be selected from the Display All screen by selecting the Turn Angle icon. At the end of an alignment procedure, the printout will show turning angle specifications along with the values entered.

JACK & HOLD OVERVIEW

Raising a vehicle causes the wheels to sag, dramatically altering alignment readings.

Jack & Hold compensates for this wheel sag by comparing measurements taken while the vehicle rests on the rack to readings taken after you raise the vehicle. This allows you to make alignment adjustments on a raised vehicle as if it were on the ground.

WARNING

When raising the vehicle to perform this step, make sure the vehicle is secure so it will *not* move (use the brake pedal depressor and/or parking brake). Failure to follow this procedure could result in injury or death!

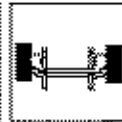

Caster Swing



Turn Angle



Jack & Hold

Display All DISPLAY ALL OVERVIEW

The Display All screen displays the following alignment measurement readings for the available alignment modes:

2-WHEEL ONLY

- Camber
- Individual Toe
- Total Toe
- Caster (if a caster swing was performed)
- Steering Axis Inclination (S.A.I.) (if a caster swing was performed).

2-WHEEL CENTER LINE

- Camber
- Individual Toe
- Total Toe
- Caster (if a caster swing was performed)
- S.A.I. (if a caster swing was performed).
- Setback

4-WHEEL THRUST LINE

Front

- Camber
- Individual Toe
- Total Toe
- Caster (if a caster swing was performed)
- S.A.I. (if a caster swing was performed)
- Setback

Rear

- Camber
- Individual Toe
- Total Toe
- Thrust Line

8-SENSOR

Front

- Camber
- Individual Toe
- Total Toe
- Caster (if a caster swing was performed)
- S.A.I. (if a caster swing was performed)
- Setback

Rear

- Camber
- Individual Toe
- Total Toe
- Thrust Line
- Setback

NOTE

Caster and SAI values are not "live." After alignment adjustments are made, caster swing must be repeated to update these values on the screen.

If specifications were entered, values that are out-of-specification appear in red. Values within specification are green. Values for which there are no specifications appear in black.



Adjustment Meters

ADJUSTMENT METERS OVERVIEW

Use these screens to see the effects of adjustments to the vehicle as they are being made.

NOTE

The Caster Adjustment meter is available only after a caster swing has been performed. This meter shows changes in caster as adjustments are made. A caster swing must be performed after making adjustments to update caster values on the Display All screen.

OPERATING TOE AND CASTER/CAMBER METERS

The operation and layout of both the Toe and Caster/Camber meter screens are very similar. Both allow you to magnify the meters and toggle between Toe and Caster/Camber.

Chapter 5: Preventive Maintenance

Preventive Maintenance

WHEEL ALIGNMENT RACK/RUNWAYS

- Runways must remain level side to side and front to rear when resting on safety legs at working height.
 - Side to side tolerance front = $\pm 1/16"$. Measure from center of Turning Radius Plate on left side to center of Turning Radius Plate on right side.
 - Side to side tolerance rear = $\pm 1/16"$. Measure from center of rear slip plate on left side to center of slip plate on right side.
 - Front to rear tolerance = $\pm 1/4"$. Measure from center of left front Turning Radius Plate to center of left rear slip plate. Then repeat front to rear measurement on right side.
- Check rack for available lubrication areas. Lubricate once every six (6) months.

FULL FLOATING FRONT TURNING RADIUS PLATES

- Plates must be disassembled once every six (6) months and bearing race cleaned.

NOTE

After bearing race is cleaned only a dry spray lubricant such as silicone or graphite should be used on the bearings. Grease or oil should never be used as it holds dirt/grit and acts as an abrasive.

Full Floating Turning Radius Plates in good working condition swivel when light hand pressure is applied.

- Use air hose to blow dirt/grit and water from bearings each day.
- Always place pins in Turning Radius Plates before front wheels of vehicle drive on or off plates.

REAR SLIP PLATES

- Use same maintenance procedure as front Turning Radius Plates.

SLIDING JACKING BEAM

- Clean oil and grease from jack pads/flip pads and slide bars each working day.

- Clean and lubricate outer surface of the roller rails (located on bottom area of Jacking Beam) once a month.
- Clean rack runway tracks where roller rails make contact once a month.

CCD ALIGNMENT SYSTEM UNIT

- C.R.T. Monitor Screen: clean once a week with window cleaner and soft cloth.
- Clear Toe/Track Lens on Wheel Units: clean once a week with window cleaner and soft cloth.
- Console Keyboard: clean once a week with spray-type household cleaner and soft cloth. Do not use a harsh cleaning agent, such as carburetor cleaner.
- Remote Keypad: clean once a week with spray type household cleaner and soft cloth. Do not use a harsh cleaning agent.
- Wheel Unit Keypad: clean once a week with spray-type household cleaner and soft cloth. Do not use a harsh cleaning agent.
- All Electrical cables: clean once a week with industrial hand cleaner and shop towel. Also, inspect cables and connectors for damage.
- Wheel Clamps
 - Screw Thread: clean and lubricate with light oil once a month.
 - Spindle: clean and lubricate with light oil once a month.
 - Center Sliding Bar: clean and lubricate with light oil once a month.
 - Hook Adapter (Claw foot): Check Hook Adapter screw daily (four on each Wheel Clamp) for tightness. If loose, tighten screw with large flat blade screwdriver.

BRAKE PEDAL DEPRESSOR

- Must be inspected for proper working condition before each use.

STEERING WHEEL HOLDER

- Must be inspected for proper working condition before each use.

© Copyright 1995, Automotive Diagnostics, A Division of SPX Corporation